

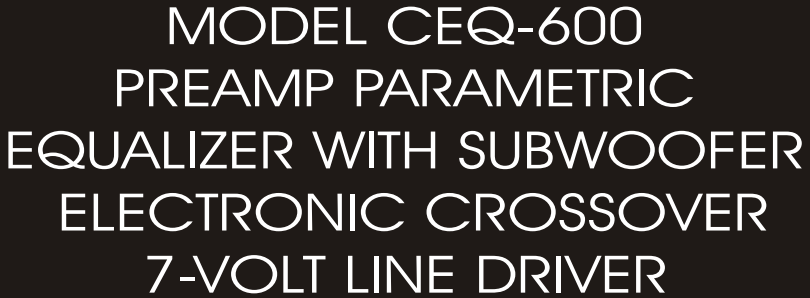

CADENCE

ULTRASHOCK



MODEL CEQ-600 PREAMP PARAMETRIC EQUALIZER WITH SUBWOOFER ELECTRONIC CROSSOVER 7-VOLT LINE DRIVER

Thank you for purchasing the Cadence Model CEQ600 preamp parametric equalizer. With proper care and installation the CEQ600 will service you with years of performance and reliability.

The CEQ600 is intended for those who value the acoustic benefits of a multi-band Parametric Equalizer / Subwoofer Crossover coupled with the power of controlling four amplifier channels and two independent sub woofer channels directly from the automobile dash board.

The CEQ600 is a passive preamp equalizer requiring external amplification to power speakers. It provides 2 channels of front output, 2 channels of rear output and 2 channels of subwoofer output.

Every car interior produces at least one sharp peak or dip in the frequency response that results in highly unnatural sound reproduction. But the exact frequency and its level of intensity depend on unpredictable factors such as the size and volume of the interior, type of material used for the interior (cloth, leather, vinyl), whether a window is open or how many passengers are on board.

Because of these variables, even a multi-band graphic equalizer will not be able to control a particular frequency without unnecessarily affecting others. The listener is therefore faced with either unwanted alteration of frequencies or having unnatural peaks and dips, which might result in boomy bass, a muddled vocal range or harsh treble response.



The purpose of the 7 Parametric frequency bands built into the CEQ600 is to allow you to tune the basic frequencies in order to correct problem in car responses. Once brought into focus, the problem frequency can then be attenuated or boosted. Precise control is therefore possible over the entire frequency range while other individual adjacent bands need not be affected.

When increasing the boost of any frequency you are actually increasing the output voltage of the equalizer to the amplifier. Please be sure that your amplifier has enough "head room" and is capable of handling the source increase without clipping. It is also important that your speakers are capable of reproducing the frequency range which you have chosen to boost without being over driven. For example, do not attempt to boost a 60Hz signal to a small midrange driver, this will only cause the midrange to burn out. The proper procedure for a successful installation is to incorporate either an electronic crossover or passive crossovers to help control which frequencies will actually reach the proper speakers.

For basic installations in a vehicle with the larger speakers in the rear and smaller speakers in the front, utilize the fader control to adjust the amount of power reaching the speakers. By turning the fader more to the rear position, more power will be distributed to the rear speakers, thereby protecting the smaller speakers in the front of the vehicle.

FEATURES & OPERATING CONTROLS.

1. **FADER CONTROL.** Allows for front to rear balancing in a four speaker system for best directional imaging. The Fader Control is located at the outer knob position around the Master Volume Control.

2. **MASTER VOLUME.** Simultaneously raises and lowers the volume of all 7 band levels.

3. **LINE INPUT SELECTOR.** Selects Line 1 or Line 2. This can be used to switch an additional components beyond the input capabilities of your head unit. For example if you wish to add a DVD or CD changer to your system, you can input the signal into the CD RCA jacks located in the rear of the CEQ600 and select the input source via the front panel switch. The top of the CEQ600 chassis features stereo Input Gain adjustments for the CD input so that you can match the input signal of your two source units to match in volume when you switch between them.

4. **PARAMETRIC EQUALIZER FREQUENCY CONTROLS.** The CEQ600 provides for 7 adjustable bandwidth ranges of equalizer control. This allows for precise control over the full frequency range. The range controls are located on the outer knobs while the inner knob controls the 18dB gain or cut. The frequency ranges are as follows: 20Hz - 80Hz, 80Hz - 160Hz, 160Hz - 320Hz, 320Hz - 800Hz, 800Hz - 2KHz, 2KHz - 10KHz, 10KHz - 20KHz.

5. **SUBWOOFER CONTROL.** The CEQ600 features separate RCA output for independent subwoofer utilization in the system. The subwoofer channels are stereo and feature an 18dB per octave Butterworth low pass crossover which is fully adjustable from 32Hz to 320Hz. The outer knob of the subwoofer knob controls the LOW PASS crossover frequency while the inner knob adjusts the volume.

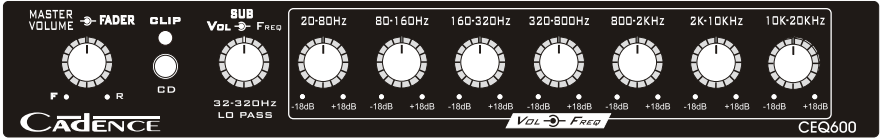

WIRING DIAGRAM



SIGNAL SOURCE

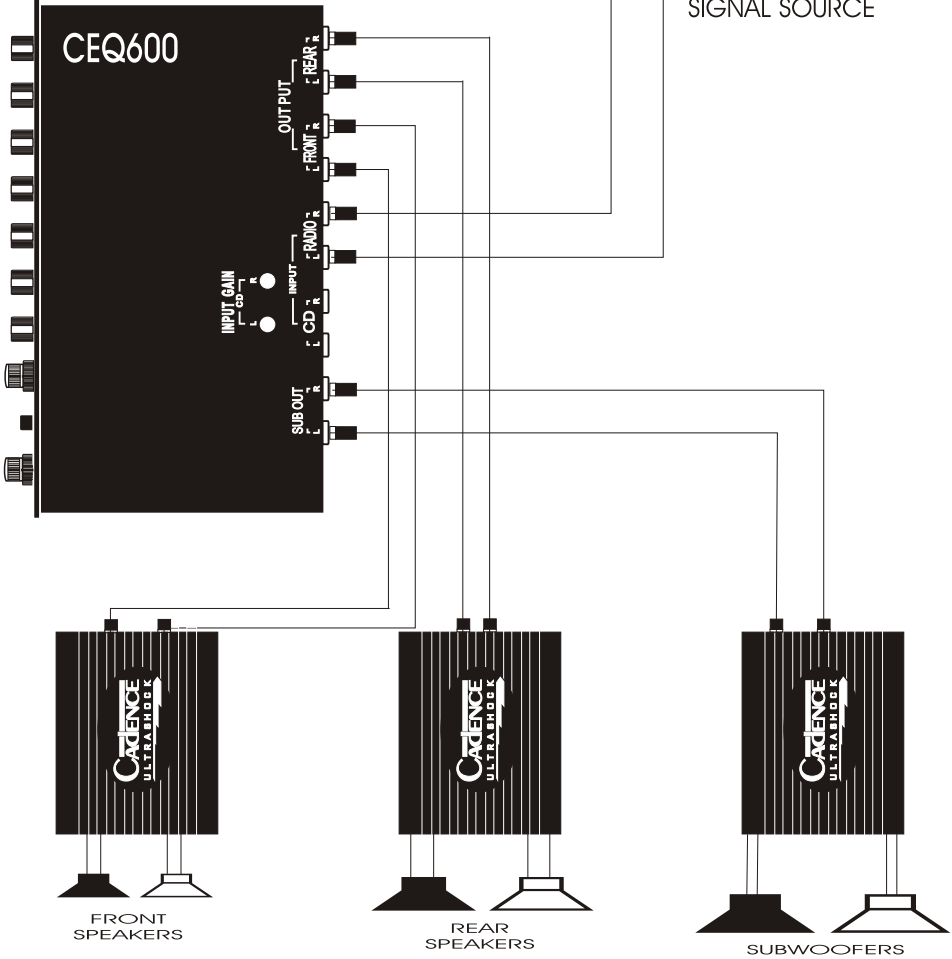

INSTALLATION.

The CEQ600 is designed for in dash installation directly above or below a standard DIN size radio/tape player or CD player controller. Installation kits are available from your dealer to help make your installation quick and simple while giving your installation a custom, built-in look.

Brackets and screws are supplied with this unit for under the dash, glove compartment or console installations. Consult your professional auto sound dealer/installer for assistance.

WIRING.

The CEQ600 is equipped with a molex type plug for power, ground and remote connections. Open the screws on top of the connector and insert the wires into the hole located directly below the screw. The CEQ600 comes standard with a lead of red color wire which is prefused. You must use this lead in the 12V+ position.

Before making any electrical connections, we suggest that you disconnect your car battery in order to avoid any shorts or blown fuses.

Use a Black colored wire to connect the CEQ600 GROUND terminal directly to the vehicles chassis.

The Red colored wire with the in-line fuse is for the main power to the CEQ600. It should be connected to a 12V+ source. This is normally the same power source which your head unit is connected to.

Use an Orange or Yellow colored wire for the remote turn on lead of the CEQ600. This wire should be connected to the radios power antenna wire or special remote lead from the radio, so that the CEQ600 will turn on with the rest of your system.

Please use high quality shielded RCA cables in order to avoid electrical noise problems. The RCA cables should be laid on the opposite side of the vehicle than any power or ground wires from the amplifiers. This will help isolate electrical noise from getting into the audio system.

OPERATIONAL CHECKS.

Begin with the radio in the off position. Set the Fader and all controls to their center positions. Switch your car ignition or accessory on and turn the radio to low volume. The illumination around the knobs should now be lit. If nothing happens, check for proper power, ground and that the fuse is not blown. If all connections have been verified correct, check that the remote wire is actually getting power.

To the "do-it-yourselfer", if you are sure of all your connections and the unit still does not operate properly, we request that you seek qualified help to verify that the installation was done properly before exchanging or sending back the unit for repair.

If your system turned on, slowly raise the volume of the CEQ600-the volume should increase from all your speakers. Rotate your radio balance in conjunction with the CEQ600 fader to make sure that the sound is moving correctly from left to right and front to rear. It is important that your radio fader and balance be left in their center positions.

LINE DRIVER.

The CEQ600 has a built-in DC to DC fully isolated power supply and is capable of producing up to 7 volts of audio output through the RCA preamp connections. The Line Driver feature will guarantee a strong audio signal to the amps and ensure clean distortion free audio reproduction.

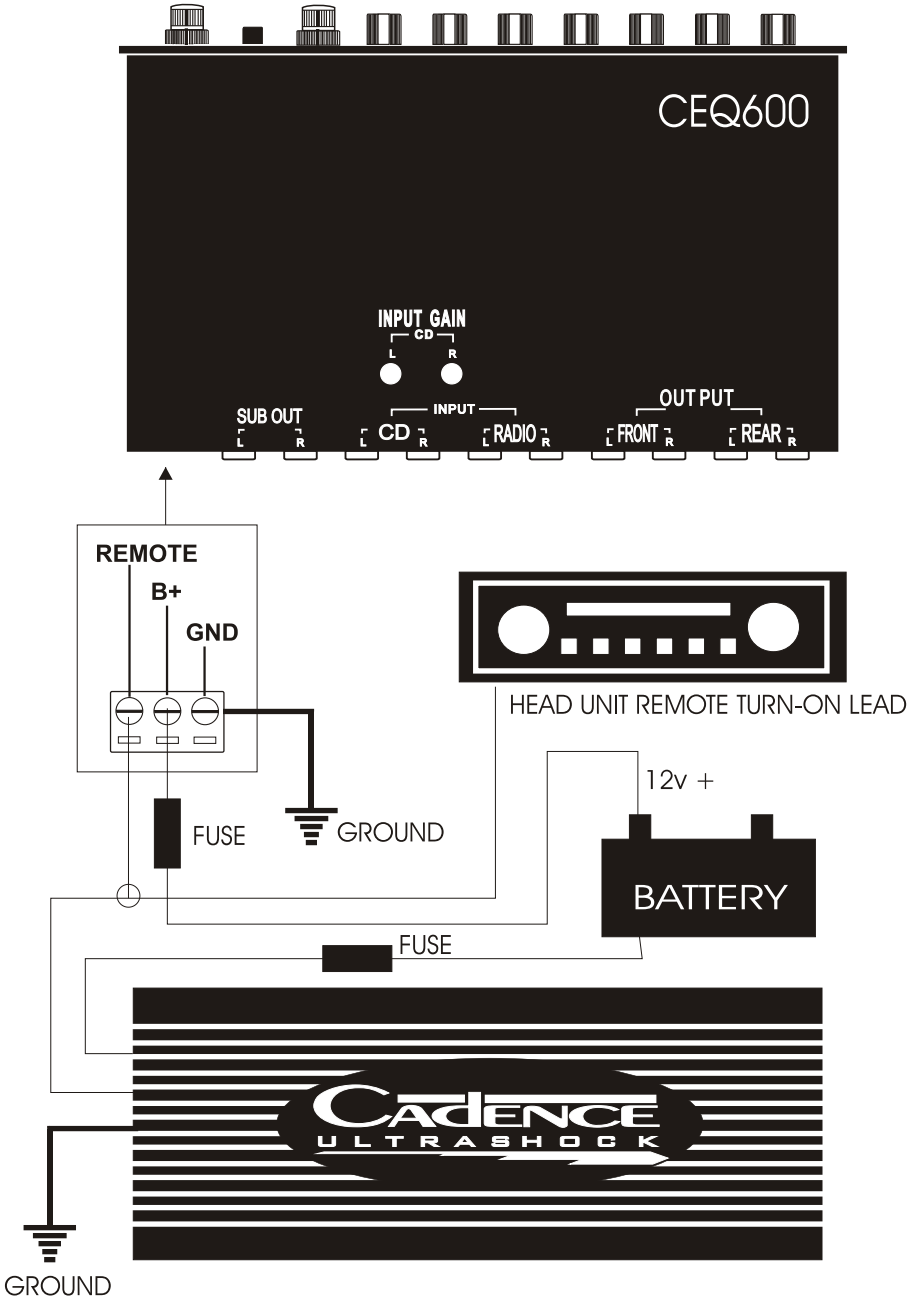

WIRING DIAGRAM DUAL SIGNAL SOURCE

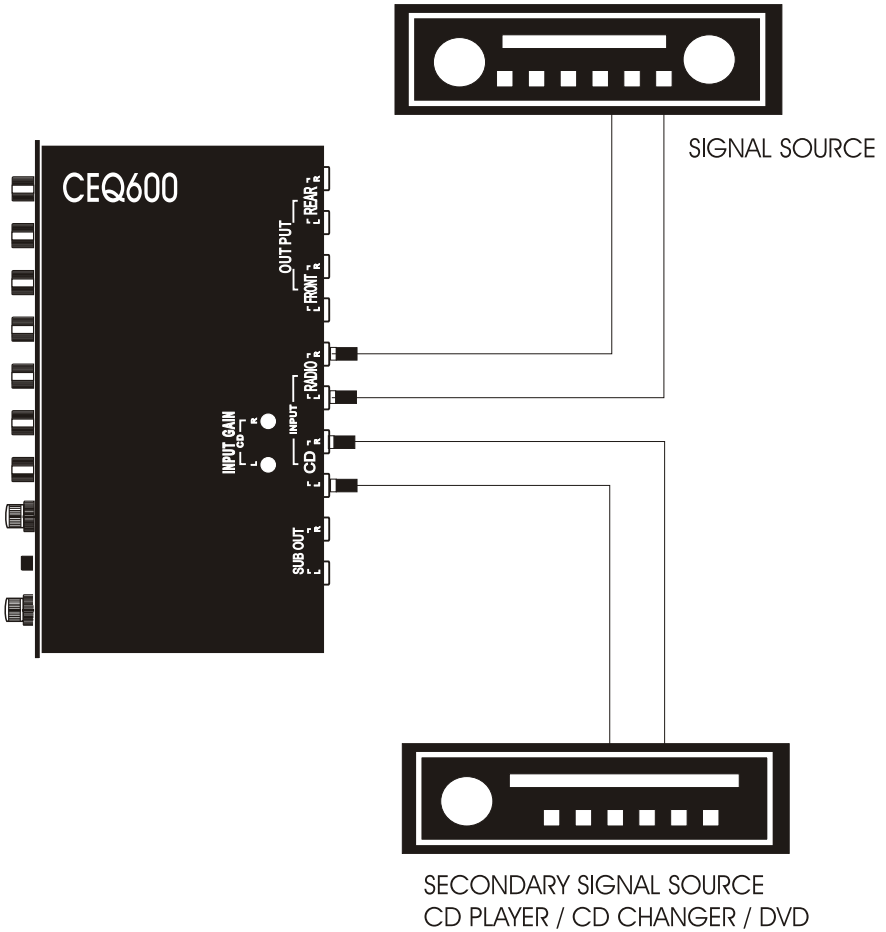

LINE INPUT SELECTOR. Selects Line 1 or Line 2. This can be used to switch an additional components beyond the input capabilities of your head unit. For example if you wish to add a DVD or CD changer to your system, you can input the signal into the CD RCA jacks located in the rear of the CEQ600 and select the input source via the front panel switch. The top of the CEQ600 chassis features stereo Input Gain adjustments for the CD input so that you can match the input signal of your 2 source units to match in volume when you switch between them.

ADJUSTING THE SYSTEM.

Once you are certain that all the wiring is correct and that the unit turns on properly you are ready to adjust the audio section.

1. Disconnect the amplifiers remote turn on leads.
2. Adjust all amplifier gains to minimum.
3. Turn the Master Volume of the CEQ600 to maximum.
4. Turn the volume of your head unit to maximum and then down a drop or until the CLIP LED begins to blink. You do not want the CLIP LED to be in a constant on position. Please note that the CLIPPING LED circuit is as accurate as a scope in measuring square waves in the audio signal. If the CLIP LED is constantly on, you are sending DC to your speakers and they will eventually burn out. Use the CLIP LED to monitor your system output. It is normal for the CLIP LED to blink on during heavy bass notes.
5. If you have a secondary sound source such as a CD changer, CD player or DVD hooked into the CD input of the CEQ600, switch that source on. Now adjust the Input Level controls found on the top of the CEQ600 chassis until the CLIP LED begins to blink.
6. Reduce the Master Volume of the CEQ600 and reconnect the remote turn on leads to the amplifiers.
7. Restart the system and increase the volume of the CEQ600 to your desired listening pleasure.
8. The CEQ600 should be able to run the system even with the amplifier gains set to minimum. If you can not reach your desired listening level you may raise the amplifier gains. Setting amplifier gains unnecessarily to maximum can cause noise problems in your system.

SPECIFICATIONS

Parametric Equalizer Frequencies

Band One Range	20Hz - 80Hz Sub Bass
Band Two Range	80Hz - 160Hz Bass
Band Three Range	160Hz - 320Hz Mid Bass
Band Four Range	320Hz -800Hz Midrange
Band Five Range	800Hz - 2KHz Mid/Hi Range
Band Six Range	2KHz - 10KHz Tweeter
Band Seven Range	10KHz - 20KHz Super Tweeter
Equalization Control	Boost/Cut 18dB
Frequency Response	10Hz - 50KHz
LP Crossover	32Hz - 320Hz 18dB per octave
Total Harmonic Dist.	<0.05%
Signal to Noise Ratio	105dB
Maximum Output Level	7 Volts RMS
Dimensions	7" x 1" x 4.5" (WxHxD)

Due to our continuing efforts towards product improvement, the above specifications are subject to change without notice. Not responsible for typographic errors. Copyright Cadence Sound Systems 2000.

